



HAL
open science

Citrulline: from metabolism to therapeutic use.

Senda Bahri, Naima Zerrouk, Christian Aussel, Christophe Moinard, Pascal Crenn, Emmanuel Curis, Jean-Claude Chaumeil, Luc Cynober, Souad Sfar

► **To cite this version:**

Senda Bahri, Naima Zerrouk, Christian Aussel, Christophe Moinard, Pascal Crenn, et al.. Citrulline: from metabolism to therapeutic use.. Nutrition, 2013, 29 (3), pp.479-84. 10.1016/j.nut.2012.07.002 . inserm-00924338

HAL Id: inserm-00924338

<https://inserm.hal.science/inserm-00924338v1>

Submitted on 6 Jan 2014

HAL is a multi-disciplinary open access archive for the deposit and dissemination of scientific research documents, whether they are published or not. The documents may come from teaching and research institutions in France or abroad, or from public or private research centers.

L'archive ouverte pluridisciplinaire **HAL**, est destinée au dépôt et à la diffusion de documents scientifiques de niveau recherche, publiés ou non, émanant des établissements d'enseignement et de recherche français ou étrangers, des laboratoires publics ou privés.

Citrulline: from metabolism to therapeutic use

Running title: citrulline: metabolism and therapeutic

Senda Bahri Hicheri^{1,2}, PhD; Naima Zerrouk², PhD; Christian Aussel³, PharmD, PhD; Christophe Moinard³, PhD; Pascal Crenn⁴, MD, PhD; Emmanuel Curis⁵, PhD; Jean-Claude Chaumeil², PharmD, PhD; Luc Cynober³, PharmD, PhD; Souad Sfar¹, PhD.

¹Laboratoire de pharmacie galénique, Faculté de pharmacie. Monastir, Tunisie.

²Laboratoire de pharmacie galénique-Faculté de pharmacie Université Paris Descartes. Paris, France.

³Laboratoire de biologie de la nutrition, EA 4466, Faculté de pharmacie Université Paris Descartes. Paris, France

⁴EA 4497, Université Versailles Saint Quentin en Yvelines, Hôpital Raymond Poincaré (APHP), Garches, France.

⁵Laboratoire de biomathématiques-Faculté de pharmacie Université Paris Descartes. Paris, France

⁶Service de Biochimie interhospitalier Cochin Hôtel Dieu, AP-HP, Paris, France

Statement of authorship

S Bahri Hicheri wrote the manuscript. All the other authors read and corrected the manuscript.

Word count: 5047

Number of figures and tables: 1 figure, 2 tables

Correspondence: Dr Senda BAHRI HICHERI

Laboratoire de pharmacie galénique, Faculté de pharmacie de Monastir, Rue Avicenne. 5000. Monastir, Tunisie.

e-mail : sendabahri@hotmail.com

Abstract

Citrulline displays a highly specific metabolism. Citrulline bypasses the splanchnic extraction; it is neither used by the intestine nor taken up by the liver. Thus the administration of citrulline may be utilized to deliver nitrogen making it available for the protein homeostasis in peripheral tissue and as an arginine precursor synthesized *de novo* in the kidneys, in endothelial and immune cells. A recent work showed that citrulline is efficiently transported across the intestinal luminal membrane, using a set of transporters belonging to systems B⁰⁺, L, b⁰⁺. Several pharmacokinetic studies confirm that citrulline is efficiently absorbed when orally administered. Oral citrulline could be used either as a method to deliver arginine to the systemic circulation or as a protein anabolic agent in specific clinical situations: recent data suggest that citrulline, while not a component of proteins, stimulates protein synthesis in skeletal muscle through the mTOR signalling pathway. Hence, citrulline could play a pivotal role in maintaining protein homeostasis and is a promising pharmaconutrient in nutritional strategies in malnourished patients, especially in aging and sarcopenia.

Key words: citrulline, metabolism, transport, pharmacokinetics, arginine

1. Introduction

Citrulline was firstly identified and isolated from the juice of watermelon, *Citrullus vulgaris* (1). This amino acid attracted relatively little interest until recently because it is a non protein amino acid and considered solely as an intermediate metabolite in ureagenesis (2, 3). However, in the last decade interest about citrulline has risen substantially because of its very specific metabolism.

Since citrulline is almost exclusively synthesized by the intestine, plasma citrulline has been identified as a biomarker of functional small bowel enterocyte mass (for recent reviews see 4, 5). In addition, as kidney is the main organ that metabolizes citrulline into arginine, renal failure is associated with an impairment of citrulline metabolism. The increase in plasma citrulline has been reported to be a potential marker of renal function (6). These features highlight the major role of intestine and kidneys in citrulline production and disposal respectively.

As it is a precursor of arginine, citrulline is also being investigated as a supplement from which arginine can be synthesized. In addition, arginine can be recycled from citrulline in some cells and this is of major importance in the so-called nitric oxide (NO) cycle. Hence citrulline can act as an arginine precursor for NO synthesis (7) and plays an important role in the metabolism and regulation of NO (8). Therefore, its administration may constitute a therapeutic strategy for controlling NO metabolism disorders and improving cardiovascular function. Citrulline supplementation should be considered for use in all circumstances or disease states in which arginine has beneficial effects and/or where arginine supplementation may be considered as harmful (9). Moreover, aging is associated with high splanchnic sequestration of amino acids and sarcopenia (10). Citrulline escapes splanchnic extraction and can stimulate muscle protein synthesis (11). Thus administering citrulline is a tool to deliver adequate amounts of nitrogen to peripheral tissues, including the muscle, in elderly.

Therefore, citrulline administration has potential beneficial effects in different situations. In this review paper, we report experimental data of pharmacokinetic studies and clinical trials involving oral administration of citrulline as an alternative to arginine. As citrulline bioavailability is dependent on its intestinal absorption and amino acid transport systems may regulate substrate availability for citrulline-requiring enzymes in the intestine, a brief description of citrulline amino acid transport systems will be done.

2. Metabolism of citrulline

2.1. Citrulline transport studies in intestinal models

In the rat intestine, citrulline absorption seems to be optimal between the median and lower ileum (12). In addition, there is no evidence for an increased or decreased uptake of L-citrulline by enterocytes under low or high protein or L-citrulline intake (8).

While citrulline transport in several cell types is well characterised (Table 1), currently transport mechanism of L-citrulline in the intestine is poorly documented. There are only two reports describing a concentration gradient transport across the everted sacs of the rat intestine (13) and an active transport by a neutral amino acid transport system in the hamster intestine (14). It was also showed in everted sacs of the small intestine that citrulline transport is mediated by a carrier-mediated active transport (12). Competition studies revealed the implication of NBB system. This system corresponds to the system B⁰ (15). L-citrulline could also be transported by a system analogous to system ASC (12).

In Caco-2 cells, a model for intestinal uptake studies, we have characterized kinetics of citrulline uptake (16). At the apical side, citrulline uptake involved a Na⁺- dependent transporter (System B^{0,+}) and a Na⁺- independent saturable transport including systems L and

$b^{0,+}$ and no saturable diffusion. These transport systems take up citrulline from the lumen with comparable activities (table 1). It can be hypothesized that this large spectrum of transport systems compensates for the low content of citrulline in food, which may be important given the key role of citrulline in arginine *de novo* synthesis (16).

Citrulline transport has also been characterized in several other cell types: macrophages (17), rat aortic smooth muscle cells (18), neural cell cultures (19) and bovine aortic endothelial cells (20) (Table 1).

2.2. Intestinal metabolism of citrulline

Intestinal citrulline production originates mainly from the proximal small bowel and probably from the middle and upper parts of intestinal villi (4).

Glutamine is generally considered as the major precursor of citrulline in the intestine (7). Citrulline is one of the end products of glutamine metabolism accounting for 27.6 % of metabolized glutamine (21). The synthesis of citrulline from glutamine involves five mitochondrial enzymes: phosphate-dependent glutaminase (PDG), pyrroline-5-carboxylate synthase (P5CS), ornithine aminotransferase (OAT), OCT (ornithine carbamoyltransferase) and CPSI (carbamoyl phosphate synthetase I) (22). Key regulation enzymes are OAT and P5CS which are unique to small intestinal enterocytes (23). This metabolic pathway is summarized in figure 1.

Besides, glutamine and some other amino acids can contribute to the intestinal production of citrulline. Indeed, citrulline can be synthesized from arginine because enterocytes possess the enzyme arginase which transforms arginine into ornithine (24). Ornithine is then converted into citrulline via OCT. Whether glutamine or arginine is the major precursor of citrulline is now controversial (25, 26).

2.3. Whole body inter-organ exchanges and catabolism

Following release from enterocyte, citrulline passes through the liver without major metabolism and reaches the systemic circulation. The liver does not contribute significantly to circulating citrulline levels (21). Human liver might be capable of taking up a substantial amount of intestinal derived citrulline and thus limiting the amount of citrulline reaching the kidney (27). However in that study, the subjects were studied per-operatively for cancer. It cannot be excluded that liver bearing cancer expresses citrulline transporters which do not exist in normal liver.

The kidney is the major consumer of circulating citrulline. It takes up about 1.5 g citrulline per day from the blood (28). Approximately 83% of the citrulline released by the gut is metabolized within the kidney, and this represents 35% of circulating citrulline (21). 75 % of the citrulline extracted from the blood is converted stoichiometrically into arginine through a partial urea cycle by argininosuccinate synthetase (ASS) and argininosuccinate lyase (ASL) (23, 29). Synthesized arginine is released into the renal vein and then to systemic blood circulation (28). Citrulline converted by the kidney is enough to sustain whole body arginine requirements. Arginine synthesized from citrulline represents 60% of the *de novo* arginine synthesis in the organism, but only 5 to 15% of circulating arginine (30).

3. Pharmacokinetics of citrulline

Mandel et al. (1) studied the response of plasma citrulline and arginine to ingestion of watermelon in healthy volunteers. A one-time intake of watermelon increased plasma concentrations of citrulline and arginine when measured immediately after ingestion (Table 2) and then declined to baseline concentrations at 8 h post watermelon ingestion. The study is limited by uncertainty as to the actual amount of citrulline ingested, but the mean citrulline intake was likely around 7 g. Collins et al.(31) investigated whether watermelon juice

consumption increases fasting concentrations of plasma arginine, ornithine and citrulline in healthy humans. In contrast to Mandel *et al.* (1), they used long-term feeding with watermelon (31). Three weeks of daily ingestion of 6 cups of watermelon juice elevated plasma arginine and ornithine concentrations (table 2). No significant changes in fasting plasma citrulline were found. This is due to the high turnover rate of arginine and citrulline.

In conclusion, dietary supplementation with citrulline is an effective alternative to oral administration of arginine. Hence watermelon may have important implications for preventing and treating diseases involving arginine deficiency (31). However, the use of large volume of watermelon juice raises the question of good compliance in the context of long term feeding.

In healthy volunteers, Moinard *et al.* (32) performed a dose-ranging study of citrulline oral administration. After citrulline load, plasma citrulline and arginine concentrations increased proportionally to citrulline load rapidly and massively and returned to baseline after 5-8 h. However, at the highest dose (15 g), arginine production was not related to the dose administered, suggesting that citrulline to arginine conversion in the kidney may be limiting and that saturation begins to occur at around this dose of citrulline. Therefore, Moinard *et al.* (32) suggest that a 10 g dose should be the most appropriate for use in clinical practice. Plasma concentrations of amino acids other than ornithine and arginine are not affected by citrulline supplementation (31, 32). This means that citrulline is a compartmentalized amino acid performing a specific job in terms of arginine metabolism (32).

Rougé *et al.* (33) also found that oral administration of citrulline can be used to enhance systemic citrulline and arginine availability and nitrogen balance. Citrulline is highly bioavailable, since systemic citrulline rose dramatically whereas urinary citrulline loss was minimal (32, 33).

Moreover, Kuhn *et al.* (34) observed that oral citrulline is more effective than arginine itself in elevating circulating arginine levels (table 2) and speculate that it may be more effective in

raising nitric oxide levels in patients with pulmonary hypertension. This observation is confirmed by the study of Schwedhelm *et al.* (35). Pharmacokinetic parameters were calculated after 1 week of oral supplementation of six different dosing regimens of placebo, citrulline and arginine (Table 2). Oral citrulline supplementation raised plasma arginine concentration and increased NO-dependent signalling in a dose dependent manner. Besides, at the dose of 3 g, citrulline was more efficient in increasing C_{max} , C_{min} and AUC over baseline placebo than arginine itself.

A recent study (36) compared the pharmacokinetics of citrulline, arginine and glutamine supplied orally, in catabolic conditions in rats. Endotoxemia considerably decreased citrulline bioavailability, whereas it did not affect arginine and glutamine pharmacokinetics. These results could have important clinical implications. However, if the target of citrulline supplementation is to use it as an arginine precursor, citrulline remained a better arginine precursor than arginine itself in this pathological condition (36). However, if the target is the specific anabolic properties of citrulline (see below), it may certainly be better to provide citrulline by the parenteral route.

Finally, the rapid disappearance of citrulline from the blood may be a disadvantage if we consider that high citrulline plasma level may trigger its action. For this purpose, galenic formulations have been established to sustain its plasma level (37).

4. Perspectives for therapeutic use of citrulline

4.1. In malnutrition state

4.1.1. Malnutrition associated to intestinal failure

Citrulline is lowered after a large intestinal resection leading to intestinal failure (38), in villous atrophy (39) or in HIV enteropathy (40). Recent papers discuss the interest of citrulline concentration as an indicator of acute intestinal failure in critically ill patients (41)

or as marker of bowel adaptation in children with short bowel syndrome (42). Since citrulline and subsequently arginine concentrations are decreased in these situations, arginine supplementation seems logical, arginine becoming essential (43). Nevertheless, arginine undergoes significant liver uptake and its metabolism (e.g. into NO) raises concerns over whether arginine supplementation may potentially be unsafe (9). Last but not least, arginine is relatively badly absorbed by the intestine, leading to intestinal discomfort and diarrhea when given at high dosage (44). Conversely, citrulline has very high bioavailability (45).

In experimental intestinal resection, one study has supplemented citrulline instead of arginine by enteral route (43) whereas a second study used citrulline by parenteral route (46). In the first study, rats were assigned to four groups: citrulline, arginine, controls and shams. The latter underwent transection while the three other groups underwent 80% resection of the small intestine. Plasma and muscle arginine concentrations were higher in the citrulline group than in the other groups. Nitrogen balance was preserved in citrulline-treated resected rats but not in arginine-supplemented rats. In the parenteral study (46), rats were assigned to four groups as in the previous study. Both citrulline and arginine increased mucosal protein content in the ileum. However, only citrulline prevented extensor digitorum longus atrophy. In addition, arginine worsened nitrogen balance whereas citrulline was unable to improve it, in contrast with enteral citrulline supplementation (43). Only citrulline was able to prevent muscle atrophy. This was achieved independently of any noticeable effect on the gut, since citrulline and arginine shared the same positive effect on mucosal ileal protein content. To date there is no data on the potential effects of citrulline on intestinal adaptation.

4.1.2. Aging and sarcopenia

Aging is associated with a progressive loss of muscle mass and function (47). In elderly, sarcopenia is associated to a reduced post prandial rate of muscle protein synthesis (48). This

may be due to a higher splanchnic extraction in the elderly (49) which implies that fewer amino acids reach the systemic circulation (50). Increasing the overall availability of amino acids can enhance protein synthesis in skeletal muscle by increasing the activities of positive regulators of translation initiation factors (47). Only one amino acid (i.e. leucine) was firmly proven to have a direct effect on muscle protein synthesis (51). This amino acid can activate several intracellular signals involved with initiating translation, the mammalian target of rapamycin (mTOR) signaling pathway, which includes 70-kda ribosomal protein S6 kinase (S6K1) and eukaryotic initiation factor 4E binding protein-1 (4E-BP1) (47). Recently it has been shown that dietary arginine supplementation increased mTOR signaling activity in skeletal muscle of neonatal pigs (52). The arginine treatment enhanced the formation of the active eIF4E·eIF4G complex and reduced the amount of the inactive 4E-BP1·eIF4E complex in muscle (52).

Citrulline supplementation led to increase in muscle protein content as well as muscle protein synthesis in elderly malnourished rats (11). It can directly stimulate protein synthesis particularly in the myofibrillar and sarcoplasmic protein synthesis (53). This amino acid activates the phosphorylation of proteins in the mTOR signaling pathway. Further study (54) using the same model support the idea that citrulline action is modulating protein synthesis through mTOR since this effect was counteracted when muscles were incubated in presence of rapamycin.

Recently, Faure *et al.* (55) demonstrated that muscle mass and motor activity significantly increased during refeeding of malnourished aged rats with citrulline. This study demonstrates the ability of citrulline to modulate muscle function. Of major interest, a recent study (56) indicates that orally administered citrulline increases muscle protein synthesis in healthy volunteers fed a hypoprotein diet, compared to isonitrogenous control.

4.2. Cardiovascular diseases

In most studies, citrulline was investigated as a supplement from which arginine can be synthesized or as a NO precursor. In children undergoing surgical procedures for congenital heart lesions, oral citrulline supplements safely increased plasma citrulline and arginine concentrations compared with placebo and improved NO production (57). The arginine level was maintained in these patients, whereas it decreased in patients receiving the placebo. Increased plasma citrulline concentrations were associated with a decreased risk of postoperative pulmonary hypertension.

In sickle cell disease, citrulline had also a systemic vasodilator antihypertensive effect (58). Administered orally, citrulline improved cardiac performance with exercise and sense of well-being. It reduced total leukocyte counts and neutrophil counts (58).

4.3. Safety issues

Citrulline is generally recognized as safe for oral use (8). At the opposite of arginine or ornithine that induces gastrointestinal side effects at high dosage (i.e. > 10 g in one bolus) (44), citrulline is well tolerated (31, 32, 35, 57, 58). This could be explained by rapid saturation of the intestinal absorption of arginine and ornithine which induce osmotic diarrhoea at high loads (32, 44). This difference between these amino acids suggests that intestinal absorption of citrulline is not a limiting step in citrulline bioavailability, even at high citrulline loads.

5. Conclusion

The intestinal epithelium plays a central role in maintaining citrulline homeostasis by systemic providing citrulline. Citrulline is easily absorbed by the gut with a broad set of transporters that can carry it from the intestinal lumen in the enterocyte. This is confirmed by the result of pharmacokinetic studies. The major finding of these studies is that oral administration of L-citrulline efficiently increases L-arginine plasma concentrations. Moreover, giving citrulline is more efficient to provide systemic arginine than giving arginine itself, likely because it bypasses metabolism in the liver and it is not a substrate for arginase. Therefore, the use of citrulline as a pharmaconutrient is a promising treatment in diseases involving arginine deficiency. Another promising field of research for citrulline is its role in protein synthesis.

References

1. Mandel H, Levy N, Izkovitch S, Korman S H. Elevated plasma citrulline and arginine due to consumption of *Citrullus vulgaris* (watermelon). *J Inher Metab Dis* 2005;28:467-472.
2. Curis E, Nicolis I, Moinard C, Osowska S, Zerrouk N, Benazeth S et al. Almost all about citrulline in mammals. *Amino Acids* 2005;29:177-205.
3. Moinard C, Cynober L. Citrulline: a new player in the control of nitrogen homeostasis. *J Nutr* 2007;137:1621S-1625S.
4. Crenn P, Messing B, Cynober L. Citrulline as a biomarker of intestinal failure due to enterocyte mass reduction. *Clin Nutr* 2008;27:328-339.
5. Crenn P, Cynober L. Effect of intestinal resections on arginine metabolism: practical implications for nutrition support. *Curr Opin Clin Nutr Metab Care* 2010;13:65-69.
6. Lau T, Owen W, Yu Y M, Noviski N, Lyons J, Zurakowski D et al..Arginine, citrulline, and nitric oxide metabolism in end-stage renal disease patients. *J Clin Invest* 2000;105:1217-1225.
7. Wu G. Intestinal Mucosal Amino Acid catabolism. *J Nutr* 1998; 128:1249–52.
8. Romero M J, Platt D H, Caldwell R B, Caldwell R W. Therapeutic use of citrulline in cardiovascular disease. *Cardiovasc Drug Rev* 2006;24:275-290.
9. Heyland DK, Dhaliwal R, Drover JW, Gramlich L, Dodek P. Canadian clinical practice guidelines for nutrition support in mechanically ventilated, critically ill adult patients. *JPEN* 2003;27:355-373.
10. Fujita T, Yanaga K. Association between glutamine extraction and release of citrulline and glycine by the human small intestine. *Life Sci* 2007;80:1846–1850.

11. Osowska S, Duchemann T, Walrand S, Paillard A, Boirie Y, Cynober L et al. Citrulline modulates muscle protein metabolism in old malnourished rats. *Am J Physiol Endocrinol Metab* 2006;291:E582-E586.
12. Vadgama J V, Evered D F. Characteristics of L-citrulline transport across rat small intestine in vitro. *Pediatr Res* 1992;32:472-478.
13. Evered D F, Nunn P B. Uptake of amino acids by mucosa of rat colon in vitro. *Eur J Biochem* 1968;4:301-304.
14. Lin E C, Hagihira H, Wilson T H. Specificity of the transport system for neutral amino acids in the hamster intestine. *Am J Physiol* 1962;202:919-925.
15. Barker G A, Ellory J C. The identification of neutral amino acid transport systems. *Exp Physiol* 1990;75:3-26.
16. Bahri S, Curis E, El Wafi FZ, Aussel C, Chaumeil JC, Cynober L et al.. Mechanisms and kinetic of citrulline uptake in a model of human intestinal epithelial cells. *Clin Nutr* 2008; 27:672-680
17. Baydoun A R, Bogle R G, Pearson J D, Mann G E. Discrimination between citrulline and arginine transport in activated murine macrophages: inefficient synthesis of NO from recycling of citrulline to arginine. *Br J Pharmacol* 1994; 112:487-492.
18. Wileman S M, Mann G E, Pearson J D, Baydoun A R. Role of L-citrulline transport in nitric oxide synthesis in rat aortic smooth muscle cells activated with LPS and interferon-gamma. *Br J Pharmacol* 2003;140:179-185.
19. Schmidlin A, Fischer S, Wiesinger H. Transport of L-citrulline in neural cell cultures. *Dev Neurosci* 2000;22:393-398.

20. Hilderman R H, Casey T E, Pojoga L H. P(1),P(4)-Diadenosine 5'-tetrphosphate modulates l-arginine and l-citrulline uptake by bovine aortic endothelial cells. *Arch Biochem Biophys* 2000;375:124-130.
21. Windmueller H G, Spaeth A E. Source and fate of circulating citrulline. *Am J Physiol* 1981;241:E473-E480.
22. Lutgens L, Lambin P. Biomarkers for radiation-induced small bowel epithelial damage: an emerging role for plasma Citrulline. *World J Gastroenterol* 2007;13: 3033-3042.
23. Wu G, Morris S M, Jr. Arginine metabolism: nitric oxide and beyond. *Biochem J* 1998;336:1-17.
24. Cynober L, Le Boucher J, Vasson M P. Arginine metabolism in mammals. *J Nutr Biochem* 1995;6:402-413.
25. Marini JC, Didelija IC, Castillo L, Lee B. Glutamine: precursor or nitrogen donor for citrulline synthesis? *Am J Physiol Endocrinol Metab* 2010;299:E69-E79.
26. Ligthart-Melis GC, Vermeulen MA, van Leeuwen PA, Deutz NE. Glutamine: precursor or nitrogen donor for citrulline synthesis? *Am J Physiol* 2010;299:E683
27. Van de Poll M C, Ligthart-Melis G C, Boelens P G, Deutz N E, van Leeuwen P A, Dejong C H. Intestinal and hepatic metabolism of glutamine and citrulline in humans. *J Physiol* 2007; 581: 819-827.
28. Van de Poll M C, Soeters P B, Deutz N E, Fearon K C, Dejong C H. Renal metabolism of amino acids: Its role in interorgan amino acid exchange. *Am J Clin Nutr* 2004; 79: 185–197.
29. Levillain O. Expression and function of arginine-producing and consuming-enzymes in the kidney. *Amino acids*. 2012; 42: 1237-1252.

30. Morris SM, Jr. Arginine: beyond protein. *Am J Clin Nutr* 2006;83:508S-512S.
31. Collins J K, Wu G, Perkins-Veazie P, Spears K, Claypool P L, Baker R A, Clevidence B A. Watermelon consumption increases plasma arginine concentrations in adults. *Nutrition* 2007;23:261-266.
32. Moinard C, Nicolis I, Neveux N, Darquy S, Benazeth S, Cynober L. Dose-ranging effects of citrulline administration on plasma amino acids and hormonal patterns in healthy subjects: the Citrudose pharmacokinetic study. *Br J Nutr* 2007:1-8.
33. Rouge C, Des Robert C, Robins A, Le Bacquer O, Volteau C, De la Cochetiere M F. Manipulation of Citrulline Availability in Humans. *Am J Physiol Gastrointest Liver Physiol* 2007: 293:G1061-G1067.
34. Kuhn K P, Harris P A, Cunningham G R, Robbins I M, Summar M L, Christman B W. Oral citrulline effectively elevates plasma arginine levels for 24 h in normal volunteers. *Circulation AHA Scientific Sessions* 2006; abstract 1692:1339.
35. Schwedhelm E, Maas R, Freese R, Jung D, Lukacs Z, Jambrecina A, et al. Pharmacokinetic and pharmacodynamic properties of oral L-citrulline and L-arginine: impact on nitric oxide metabolism. *Br J Clin Pharmacol* 2007;65:51- 59.
36. El Wafi FZ, Curis E, Zerrouk N, Neveux N, Chaumeil JC, Arnaud P, et al. Endotoxemia affects citrulline, arginine and glutamine bioavailability. *Eur J Clin Invest* 2012;42: 282-289.
37. Berthe MC, Darquy S, Breulliard C, Lamoudi L, Marc J, Cynober L, et al High plasma citrulline and arginine levels ensured by sustained-release citrulline supplementation. *Nutrition* 2011;27:1168-1171.
38. Crenn P, Coudray-Lucas C, Thuillier F, Cynober L, Messing B. Postabsorptive plasma citrulline concentration is a marker of absorptive enterocyte mass and intestinal failure in humans. *Gastroenterology* 2000;119:1496-1505.

39. Creann P, Vahedi K, Lavergne-Slove A, Cynober L, Matuchansky C, Messing B. Plasma citrulline: A marker of enterocyte mass in villous atrophy-associated small bowel disease. *Gastroenterology* 2003;124:1210-1219.
40. Creann P, De Truchis P, Neveux N, Galperine T, Cynober L, Melchior JC. Plasma citrulline is a biomarker of enterocyte mass and an indicator of parenteral nutrition in HIV-infected patients. *Am J Clin Nutr* 2009;90:587-594.
41. Piton G, Manzon C, Cypriani B, Carbonnel F, Capellier G. Acute intestinal failure in critically ill patients: is plasma citrulline the right marker? *Intensive Care Med.* 2011;37:911-917.
42. Diamanti A, Panetta F, Gandullia P, Morini F, Noto C, Torre G, et al. Plasma citrulline as marker of bowel adaptation in children with short bowel syndrome *Langenbecks Arch Surg.* 2011;396:1041-1046.
43. Osowska S, Moinard C, Neveux N, Loi C, Cynober L. Citrulline increases arginine pools and restores nitrogen balance after massive intestinal resection. *Gut* 2004; 53:1781-1786.
44. Grimble G K. Adverse gastrointestinal effects of arginine and related amino acids. *J Nutr* 2007;137:1693S-1701S.
45. Cynober L. Pharmacokinetics of arginine and related amino acids. *J Nutr* 2007;137:1646S-1649S.
46. Osowska S, Neveux N, Nakib S, Lasserre V, Cynober L, Moinard C. Impairment of arginine metabolism in rats after massive intestinal resection: effect of parenteral nutrition supplemented with citrulline compared with arginine. *Clin Sci* 2008;115:159-166.
47. Fujita S, Volpi E. Amino acids and muscle loss with aging. *J Nutr* 2006;136:277S-280S.

48. Walrand S, Guillet C, Salles J, Cano N, Boirie Y. Physiopathological mechanism of sarcopenia. *Clin Geriatr Med*. 2011;27:365-385.
49. Boirie Y, Gachon P, Beaufrère B. Splanchnic and whole-body leucine kinetics in young and elderly men. *Am J Clin Nutr* 1997;65:489–495.
50. Mosoni L, Valluy MC, Serrurier B, Prugnaud J, Obled C, Guezennec CY, et al. Altered response of protein synthesis to nutritional state and endurance training in old rats. *Am J Physiol Endocrinol Metab* 1995;268:E328–E335.
51. Li F, Yin Y, Tan B, Kong X, Wu G. Leucine nutrition in animals and humans: mTOR signaling and beyond. *Amino Acids*. 2011;41:1185-1193.
52. Yao K, Yin YL, Chu W, Liu Z, Deng D, Li T, et al. Dietary arginine supplementation increases mTOR signaling activity in skeletal muscle of neonatal pigs. *J Nutr* 2008;138:867-872.
53. Moinard C, Jourdan M, Walrand S, Le Plenier S, Boirie Y, Cynober L. La citrulline exerce un effet direct sur la synthèse protéique musculaire. *Nutr Clin Metabol* 2007;21:S31-S32.
54. Le Plenier C, Walrand S, Cynober L, Moinard C. Direct action of citrulline on muscle protein synthesis: role of the MTORC1 pathway. *Clin Nutr suppl* 2011;6:20.
55. Faure C, Raynaud-Simon A, Ferry A, Daugé V, Cynober L, Aussel C, et al. Leucine and citrulline modulate muscle function in malnourished aged rats. *Amino Acids* 2012; 42:1425-1433.
56. Jourdan M, Nair KS, Ford C, Shimke J, Ali B, Will B, et al. Citrulline stimulates muscle protein synthesis at the post-absorptive state in healthy subjects fed a low-protein diet. *Clin Nutr Suppl* 2008;3:11-12.

57. Smith H A, Canter J A, Christian K G, Drinkwater D C, Scholl F G, et al. Nitric oxide precursors and congenital heart surgery: a randomized controlled trial of oral citrulline. *J Thorac Cardiovasc Surg* 2006;132:58-65.
58. Waugh W H, Daeschner C W, Files B A, McConnell M E, Strandjord S E. Oral citrulline as arginine precursor may be beneficial in sickle cell disease: early phase two results. *J Natl Med Assoc* 2001;93:363-371.

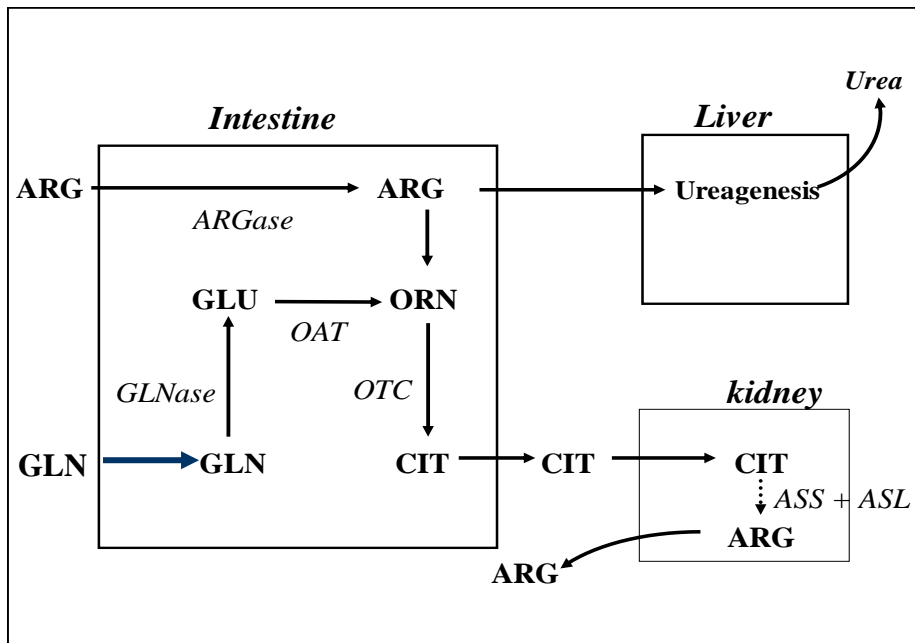

Figure 1: Interorgan metabolism of citrulline and related amino acids.

GLNase, Glutaminase; *OAT*, ornithine aminotransferase; *OCT*, ornithine carbamoytransferase; *ARGase*, arginase; ARG, arginine; CIT, citrulline; ORN, ornithine; GLN, glutamine; GLU, glutamate; *ASS+ASL*, argininosuccinate synthetase + lyase
Adapted from Crenn et al. (5). Reproduced with permission.

Table 1: Characteristics of citrulline transport across cellular membranes

Cell type	K_m (mM)	V_{max} (nmol .min ⁻¹)	Amino acid transport system	Reference
Caco-2 Cells	0.46 ± 0.07	3.58 ± 0.39	B ^{0,+}	16
	0.67 ± 0.1	2.16 ± 0.23	L and b ^{0,+}	
Rat intestinal everted sacs	4.1 ± 0.9	0.62 ± 0.06*	ASC or B ⁰	12
Aortic endothelial cell			Common transport system with arginine	20
Aortic smooth muscle cell	1.6 ± 0.2	5.9 ± 0.6	L and N	18
Astroglial cell	1.1 ± 0.1	14.7 ± 0.9	L	19
Glial cells	3.4 ± 0.2	25.6 ± 1.4		
Microglial cell	1.2 ± 0.4	31 ± 0.2		
Macrophage	0.4 ± 0.1	26.5 ± 8.7		
Macrophage	0.16 ± 0.02	32 ± 1	Neutral AA transport system with a broad specificity	17

V_{max} values are for 1mg of protein, except when marked with a star where values are for 1mg of wet tissue

Table 2: Pharmacokinetic studies of citrulline

Study	Patients	Dosage ¹	Plasma concentration achieved, $\mu\text{mol/l}$	Reference
Randomized study	10 healthy volunteers	0.18 g/kg/d	- Cit: increase of $448 \pm 92\%$ (from 39 ± 4 to 225 ± 44) - Arg: increase of $92 \pm 57\%$ (from 134 ± 33 to 247 ± 62) - Increase in urine and RBC Cit - No change in urinary Arg, nor plasma urea, urinary urea nitrogen excretion thus enhanced nitrogen balance	33
Double-blind randomized placebo-controlled cross over study	20 healthy volunteers	Cit : 0.75, 1.5 and 3 g twice daily Arg : immediate release (IR) 1g tid, sustained release (SR) 1.6 twice daily for 1 week	After load of 3 g Cit - Cit : $T_{\max} = 0.7 \pm 0.1$ h, $C_{\max} = 846 \pm 45\mu\text{mol/l}$ - Arg : $T_{\max} = 1.4 \pm 0.1$ h, $C_{\max} = 149 \pm 42\mu\text{mol/l}$	35
Simple-blind cross over study	8 healthy adult	2, 5, 10 or 15 g of Cit	After ingestion of 10 g of Cit - Cit $T_{\max} = 0.72 \pm 0.08$ h, $C_{\max} = 2756 \pm 70\mu\text{mol/l}$ - Arg $T_{\max} = 1.67 \pm 0.05$ h, $C_{\max} = 280 \pm 1043\mu\text{mol/l}$	32
Cross-over pharmacokinetic study	7 normal volunteers	Single equimolar oral dose of arg and cit 3.8 g/m ² body surface area	After oral Cit load: - Cit: increase 40 fold (from 31 ± 3 to 1275 ± 95) - Arg: increase of 227 % (from 72 ± 5 to 236 ± 5) - Arg: AUC = $1440 \pm 196\mu\text{Mxhrs}$ After oral Arg load: - Arg: increase of 90% (from 107 ± 19 to 229 ± 33) - Arg : AUC = $476 \pm 259 \mu\text{Mxhrs}$	34

Study	Patients	Dosage ¹	Plasma concentration achieved, $\mu\text{mol/l}$	Reference
Randomized placebo - controlled trial	40 children undergoing surgery to correct congenital heart lesions	Cit 1.9 g/m ² /dose x 5 Total dose of 9.5g /m ²	12h postoperative Cit : 37 (18-83) vs 20 \pm (15-29) (placebo) Arg : 36 \pm 24 vs 23 \pm 13 57 and 85% increases in mean plasma levels of Arg and Cit, respectively	57
Pilot phase II clinical trial	5 sickle cell disease patients (ages10-18)	0.09 to 0.13 g/kg twice daily for 4 weeks	Increase of 65% (from 77 \pm 9.1 to 127 \pm 18) in plasma Arg	58
Pharmacokinetic study after watermelon ingestion	6 healthy adults	3.3 kg wet weight of red fruit of ripe watermelon	- Cit: increase from 22 $\mu\text{mol/L}$ to 593 $\mu\text{mol/L}$ (range 386 - 1069) 1h after ingestion - Arg: increase from 65 $\mu\text{mol/L}$ to 199 $\mu\text{mol/L}$ (range 128 - 251) 2h after ingestion	1
Pharmacokinetic study after watermelon ingestion	23 healthy adults	780 g (<i>i.e.</i> 1 g Cit), 1560 g (<i>i.e.</i> 2 g Cit) watermelon juice for 3 weeks	- Low ingestion of watermelon juice: increase of 12 % in plasma Arg - High ingestion of watermelon juice: increase of 22 % in plasma Arg , 18% in plasma Orn.	31

¹Citrulline or otherwise stated